

<https://doi.org/10.32056/KOMAG2023.1.1>

Utility vehicle with hydraulic transmission and hybrid energy source

Received: 20.12.2022

Accepted: 01.03.2023

Published online: 03.04.2023



Author's affiliations and addresses:

¹ Hydraulics and Pneumatics Research Institute INOE 2000 – IHP Bucharest, Romania

² Hiarom Invest Ltd Dragomirești-Vale, Romania

* Correspondence:

e-mail: radoi.ihp@fluidas.ro

Radu – Iulian RĂDOI ^{1*}, **Cătălin DUMITRESCU** ¹,

Ion DAVID¹, **Marian BLEJAN**¹, **Ștefan ȘEFU**¹,

Cristian IONESCU ²

Abstract:

Considering the EU's commitment to achieve climate neutrality by 2050, new tools and investments are needed to achieve this goal. Starting from this goal, the decision was made to develop a hybrid utility vehicle with a multifunctional role, which can also be used in closed spaces such as tunnels or underground parking lots or outside, contributing to the goal of zero carbon emissions. This machine will be the basis for the further development of an electric plug-in machine with increased autonomy. The machine will use a hybrid drive with a diesel engine and an electric motor coupled to a hydrostatic transmission in a closed circuit. The machine can work in heavy environments with a lot of dust, moisture or rugged terrain where the electric motors mounted in the wheel of the vehicle do not give very good results. The traction is done on all four wheels of the machine using wheel hydraulic motors with radial pistons. This type of engine ensures a high torque at low speeds, necessary for the types of work performed. The article presents the structure of this machine, the hydraulic scheme of the actuation, the configuration of the energy group powered by a LiFePO₄ battery, through an inverter and the control system of the machine.

Keywords: utility vehicle, hybrid, electric drive, diesel, hydrostatic transmission



1. Introduction

The main novelty brought by the machine is the proposed hybrid drive. Thus, it is proposed to use a hybrid drive with a diesel engine and an electric motor coupled to a hydrostatic transmission in a closed circuit. In recent years, a number of specialists have carried out research and developed solutions in the field of hybrid machinery. The works concerned the state and development trends, patents in the field and alternative powertrain systems [1-6]. Other authors have made simulations for heavy mobile machinery [7, 8].

Starting from the requirements imposed on the multi-functional machine with zero carbon emissions for working in closed spaces, the solution of a hydrostatic actuation system with a hybrid energy source was chosen, which allows the machine to be used even after discharging the batteries. The hydrostatic system can be driven, according to requirements, with the internal combustion engine or with an electric engine as the energy source. The main technical characteristics of the machine can be found in Table 1.

The machine can work in heavy environments with a lot of dust, moisture or rugged terrain where the electric motors mounted in the wheel of the vehicle do not give very good results. The traction is done on all four wheels of the machine using wheel hydraulic motors with radial pistons. This type of engine ensures a high torque at low speeds, necessary for the types of work performed. The steering is also done on all four wheels, thus ensuring very good maneuverability, necessary for fast maneuvering. Braking is hydrostatic by reducing the flow of the pump. The car is also equipped with a normally closed parking/emergency brake, also hydraulically operated.

At the front and at the back, the machine is equipped with hydraulic couplings that allow the attachment of different hydraulic equipment.

The machine can carry out snow removal, washing, cutting vegetation, spreading non-slip material etc. for concrete platforms, and can be equipped with equipment such as cleaning brush, arm for cutting vegetation, bucket, front loader etc.

Equipment assembly can be done very easily, the machine being equipped with a standardized front fixing plate according to SR EN 15432-1:2011 and with quick hydraulic couplings for connecting the hydraulic motors from these equipments.

Table 1. Technical data

Vehicle mass	6000 kg
Electric motor power	30 kW
Diesel engine power	50 kW
Fuel tank capacity	60 l
Battery pack capacity	30 kWh
Maximum speed – working regime	7 km/h
Maximum speed – travel regime	15 km/h
Maximum traction force	30 kN

2. The structure of the utility vehicle

Two identical pumps coupled with internal combustion engine and electric motor are used thus eliminating the need to use complicated mechanical transmissions. In the papers [9-12] the authors analyzed conversion and integration technologies based on hybrid power systems, the electrification of power trains for mobile and agricultural machinery and analyzed the design and performances of the electro-hydraulic hybrid transmission system.

In the Fig. 1 can be seen the main components of the new developed machine such as: pump driven by electric motor, pump driven by diesel engine, air/hydraulic fluid cooler, hydraulic fluid tank, fuel tank, vehicle cabin and wheels with hydraulic motors inside.



The hydraulically operated mechanisms of the machine are:

- the movement mechanism, which ensures the movement of the vehicle through the 4 rotary motors with radial pistons located in the wheels, these operating in a closed circuit;
- the steering mechanism (Fig. 2), consisting of a power steering, 4 hydraulic cylinders that act to change the position of the wheels according to the direction of the turn, and 2 directional valves with electric control, thus obtaining a very good maneuverability of the 4 wheels;
- removable equipment with hydraulic actuation, intended for various maintenance works (bucket, crane etc).

Fig. 3 shows the configuration of the car's hybrid drive system. By means of some electrohydraulic directional valves, the hydraulic circuits are switched to the pump driven by the electric motor or to the pump driven by the thermal engine.

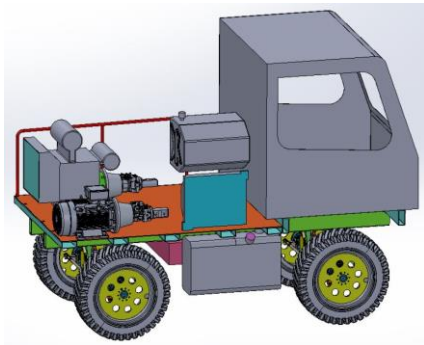

Fig. 1. 3D view with the layout of the main components of vehicle

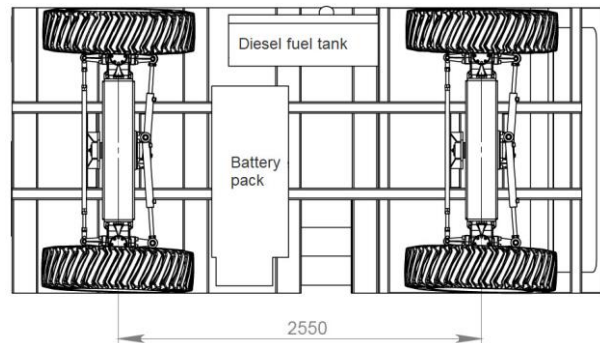

Fig. 2. Bottom view with the front and rear axles and steering mechanisms

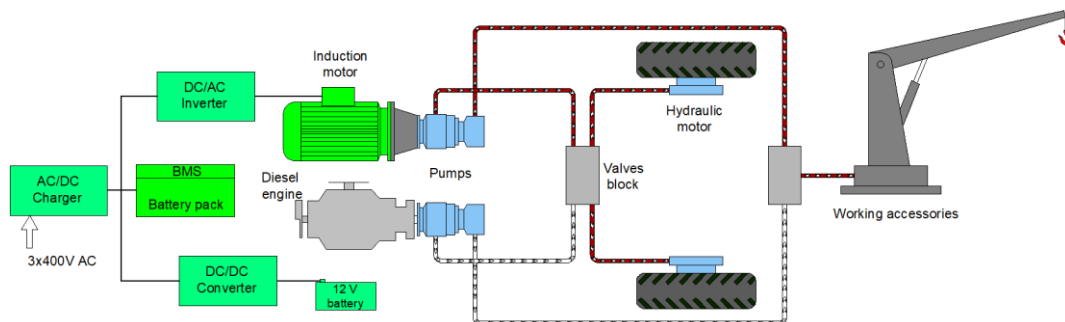

Fig. 3. The configuration of the machine hybrid drive system

3. Hydraulic drive system

The hydrostatic drive system can be activated, according to requirements, with the thermal engine or the electric engine as the energy source. Each energy group (Fig. 4) consists of: drive motor, which can be thermal – DIESEL, type Perkins 904J-E28t, $N = 50$ kW, or electric, $N = 30$ kW; pump with axial pistons (1) from Poclairn company, equipped for operation in closed circuit.

The hydraulic diagram of the actuation system highlights the ease with which the two pumping groups, electrically or thermally actuated, can be coupled to the closed circuit of the rotary hydraulic motors that make the movement; each pumping group has in its component, apart from the pump with adjustable axial pistons, also a double pump (2) with toothed wheels mounted in tandem, which ensures the supply of power steering and auxiliary equipment that can be attached through quick couplings after they have been mounted on machinery.

The POCLAIN type axial piston pump is equipped to operate in a closed circuit. The closed circuit requires the existence of a valve to ensure the maintenance of the temperature and cleanliness of

the oil within the recommended limits; the VS directional valve, hydraulically controlled, ensures the extraction of a quantity of hot oil from the low pressure branch which is sent to the auxiliary tank for cooling and filtering. To protect the environment in case of hydraulic fluid losses, biodegradable lubricant designed for hybrid vehicles can be used [13].

The auxiliary pump attached to the main pump (located in its casing) must ensure the necessary flow rate to compensate for the cooling and filtering fluid extracted by the VS directional valve, for internal or external losses from the devices and for feeding the control system, without exceeding the value of the allowed pressure.

The high-pressure valves ensure the pressure in the circuit at the required value; the check valves allow the charge flow to refill the low pressure line. The overpressure valves ensure the protection at transient high values of the high pressure loop of the circuit.

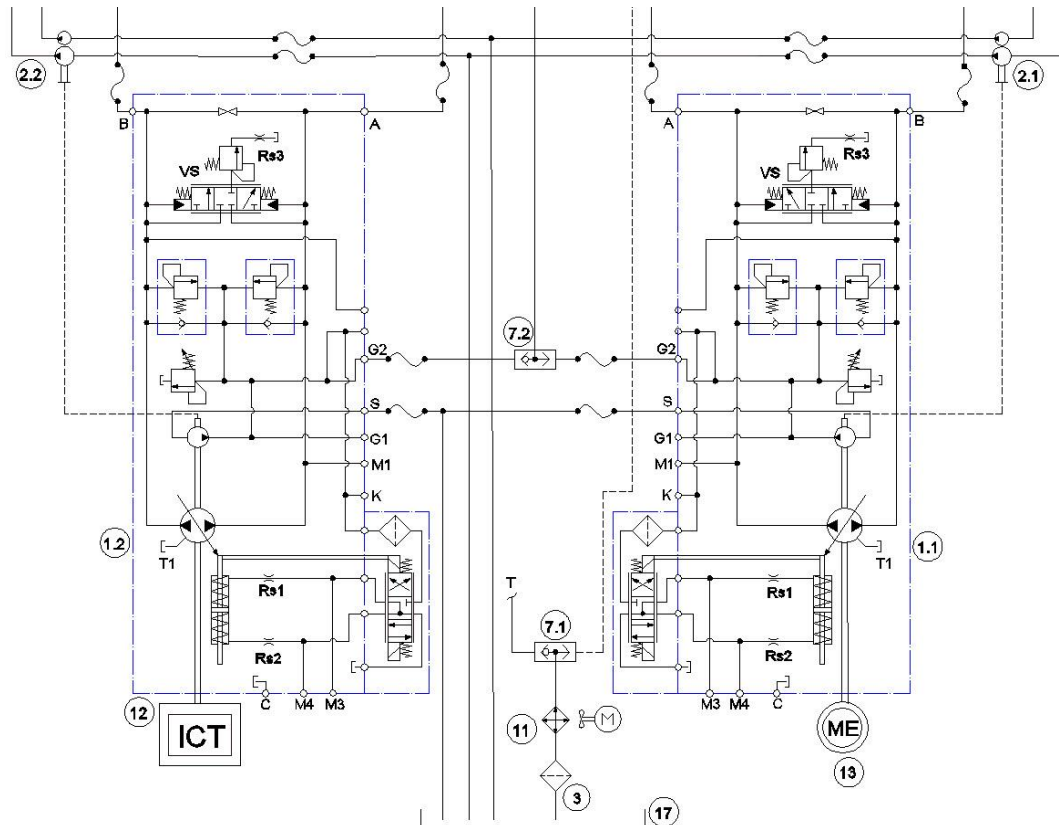

Fig. 4. Internal combustion and induction motor energy groups

These valves are not adjustable, but can be requested to be set. Flowing for a long period of time through these valves leads to excessive heating of the hydraulic fluid, which can cause damage. The related valve of the auxiliary pump ensures the loading pressure, and choosing the correct adjustment value ensures the maintenance of the pump's performance.

Adjusting the flow by changing the angle of inclination of the pump swash plate is done by applying a control current to the electro-proportional solenoids that control and adjust the pressure in the servo-control system. The flow direction depends on the activated solenoid. The reaction time can be controlled by ramps installed on the electronic control unit and by the restrictors Rs1 and Rs2 inserted between the servo control and the hydraulic servo piston. The feedback function is realized by a lever that connects the oscillating plate and the hydraulic servo piston. The presence of the two restrictors Rs1, Rs2 ensures the avoidance of sudden accelerations and stops.

In the hydraulic diagram in Fig. 4, there are also: the return filter (3), selection valves (7) which directs the flow depending on the supply source, the air-oil cooler (11), the thermal engine (12), the electric motor (13) and the hydraulic fluid tank (17).

In the Fig. 5 one can see the rotating hydraulic motors (5) mounted in the wheels of the type with radial pistons, from POCLAIN (MGE05-2-A04-101-1W20-EJ00), which can operate in two speed steps, corresponding to the two capacities, 374/749 cm³/rot. The speed synchronization of the four rotary motors is obtained using a flow divider (4), type FD-M4-POCLAIN, which is a four-way flow divider that ensures the parallel operation of the wheels on the same axle or on different axle by dividing the debit. It can work in closed or open circuits. It is equipped with a by-pass with normal opening that can be controlled electrically, VS1 and VS2. The distribution of the flow is done in two stages; first in two equal parts and then each of them in two other, equal parts, obtaining the four equal supply flows of each hydraulic motor. The divider includes the safety valves of each direction of rotation as well as the capacity change command; its modification is ordered with the help of directional valves VS1 and VS2. The coupling of the used pumping group - thermal or electric - to the circuit of the rotary motors (5) is carried out with the help of directional valves (8) (8.1 for electric drive, 8.2 for internal combustion drive) for forward movement; for going backwards, changes the discharge direction of the pump so that on the path T - A circulates the flow necessary for the hydraulic motors to achieve the speed of going backwards, this being possible because the directional valves (8) allows a pressure of up to 350 bar on the T-A circuit.

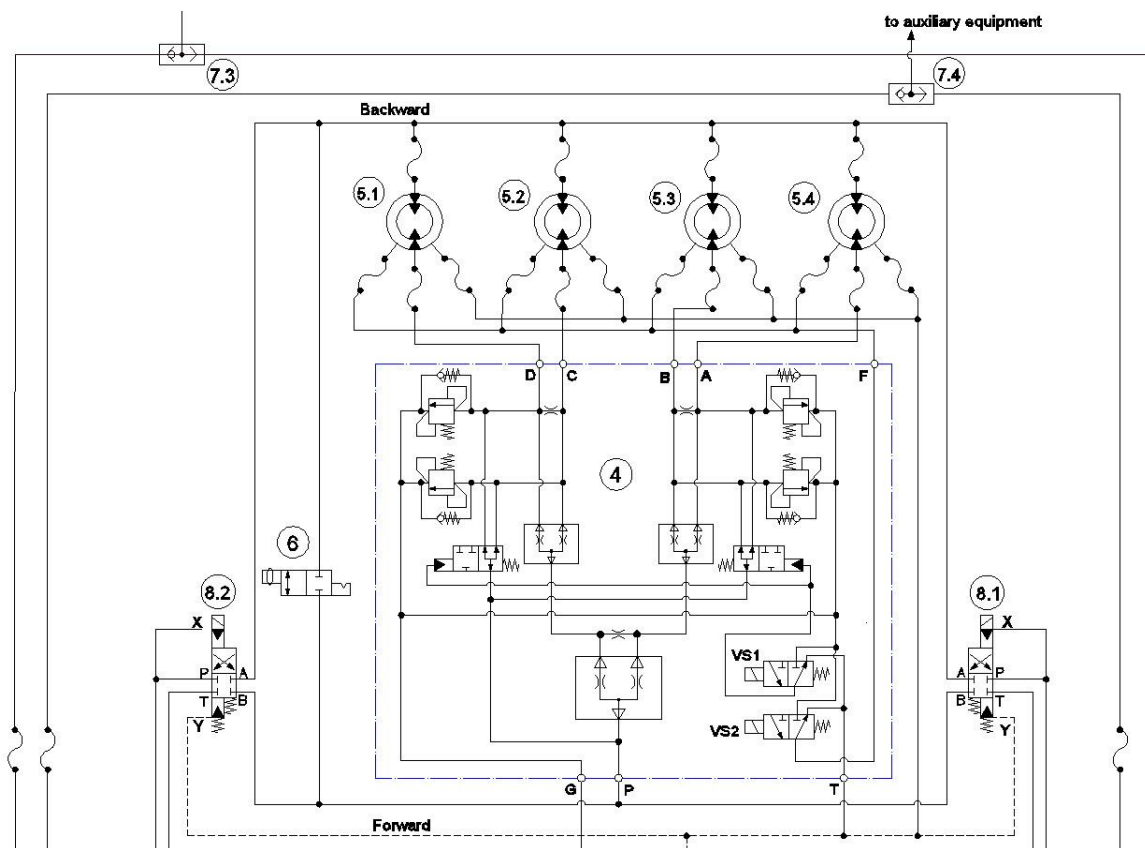

Fig. 5. Hydraulic scheme for driving hydraulic motors mounted inside wheels

In the Fig. 6 the directional valve (6) is used for emergency situations when the machine must be towed. The steering mechanism of the machine is made up of power steering (9), 4 hydraulic cylinders (10.1)÷(10.4) and two electrically controlled 4/2 directional valves (14), (15). For moving forward and turning with the two wheels from the front, power steering feeds cylinders (10.1) and (10.2); when you want to turn as small as possible, in which all 4 wheels of the machine are used, directional valve (14) is switched, and for sideways "crab walk" both directional valves, (14) and (15), are switched.

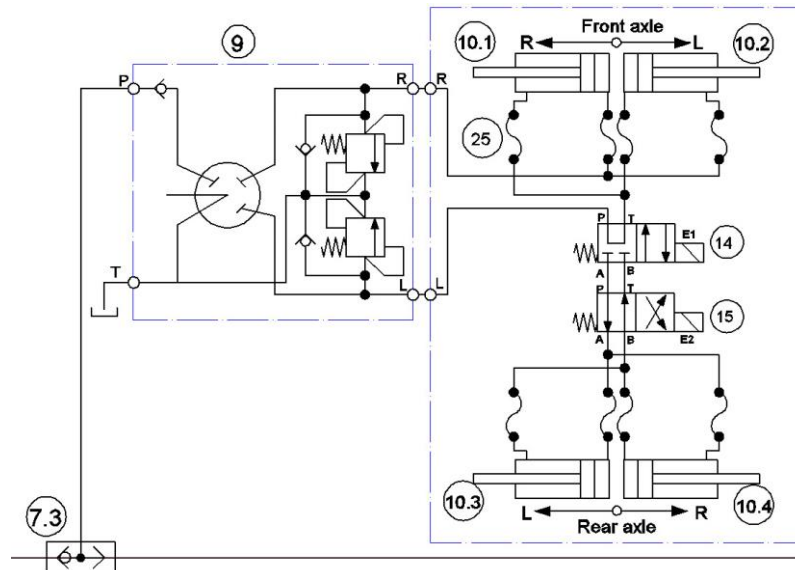

Fig. 6. Scheme of the power steering system

4. Electric drive system

The electric drive system of a hybrid utility vehicle uses a 30 kW electric motor powered by a 30 kWh battery pack through a motor controller. The electric motor drive a Poclairn pump with axial pistons equipped for operation in closed circuit. The batteries can only be charged from the mains, and in case of discharge, the diesel engine is used until reaching the garage for recharging. The diesel engine can also be used in winter conditions when the capacity of the batteries is reduced due to low temperatures. The electric drive of the machine is made with a three-phase electric motor specially designed for power supply with inverters and which resists higher voltage spikes without insulation failure (Fig. 7).

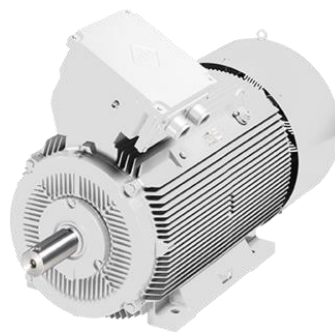

Fig. 7. Inverter fed induction motor

These motors are designed to handle lower speeds without overheating. In the case of this machine, there is no need to control the speed of the electric motor, which drives the hydraulic pumps, in a wide range, because the control of the machine's movement speed is done by the continuous variation of the pump flow rate.

The adoption of electrification and hybrid drives can contribute to increasing the energy efficiency of machinery [14]. An important problem with hybrid machinery is the energy storage systems and battery life [15, 16]. For machines that lift loads such as cranes or loaders or in the case of braking, energy recovery systems can be adopted [17, 18].

The charging of the battery pack (Fig. 8) is done by means of a charger on board (Fig. 9) which allows connection to the single-phase or three-phase electrical grid, and a DC/DC converter is used to charge the machine 12 V battery. The characteristics of the battery pack can be seen in the Table 2.



Fig. 8. Battery pack for mobile machinery from Aliant



Fig. 9. On board battery pack charger

Aliant battery pack has the main Features:

- Embedded battery management system (Pegasus proprietary)
- Integrated data logger
- USB port for diagnostic
- Parameters communication
 - SoC – State of Charge
 - SoH – State of health
 - I_{max} – Maximum current
 - V_{nom} – Nominal voltage
- Dedicated temperature management system
- Cells protection
 - Overcharge
 - Deep discharge
 - Short circuit
 - Maximum current delivered
- Optional ventilation system IP54 / fanless IP65.

Table 2. Battery pack characteristics

Energy installed	Useful Energy 80% DoD	Nominal Voltage OCV	Continuous discharge current
37632 Wh	30100 Wh	358 V nominal 20-80% SoC	105 Amp
Continuous charging current	Max charging current	Gross weight	Dimensions [mm]
105 Amp up to 80% SoC	210 Amp @25°C 5 Min 315 Amp@25°C 30 Sec Depending on SoC and Temp	310 kg	540x1400x250
Peak Discharge 30s	Energy Density	Temperature	Protection degree
210 Amp	120 Wh/kg	Discharge -30°C/60°C Charge -30°C/55°C Storage -20°C/35°C	IP54/IP65
DoD – Deep of discharge OCV – Open-circuit voltage			

Powering the electric motor is done with a controller produced by the company Inmotion type ACH (Fig. 10).





Fig. 10. Motor controller from *Inmotion*

The features of the motor controller are:

- Nominal voltage 350 / 650 V
- 4-quadrant, synchronous or asynchronous AC motor control, with speed, torque and DC voltage control modes
- Standard firmware with extensive configurability
- Application software can be configured
- Internal DC EMC filter with common mode and differential mode reduces high frequency electromagnetic interference and eliminates DC bus oscillations
- The DC EMC filter allows for free cable lengths and parallel operation of several ACH controllers and auxiliary equipment
- Vector control, adjustable for different motor types

Fig. 11 shows the block diagram of the machine's command and control system. The system uses a PLC for the management of all the car's electrical equipment. Through digital inputs, the PLC receives commands from the various buttons on the car's board to activate the solenoid valves of the hydraulic systems, to start the electric motor, activate the lights, etc. The digital outputs of the PLC effectively control, by means of relays, the solenoids of the hydraulic valves, the hydraulic fluid cooling fan, the indicator lamps, the solenoids of some relays of consumers on board etc. The pressure and temperature sensors in the hydraulic circuits, the voltage of the 12 V car battery and the control levels of the inverter and variable capacity pump controllers are monitored through the analog inputs.

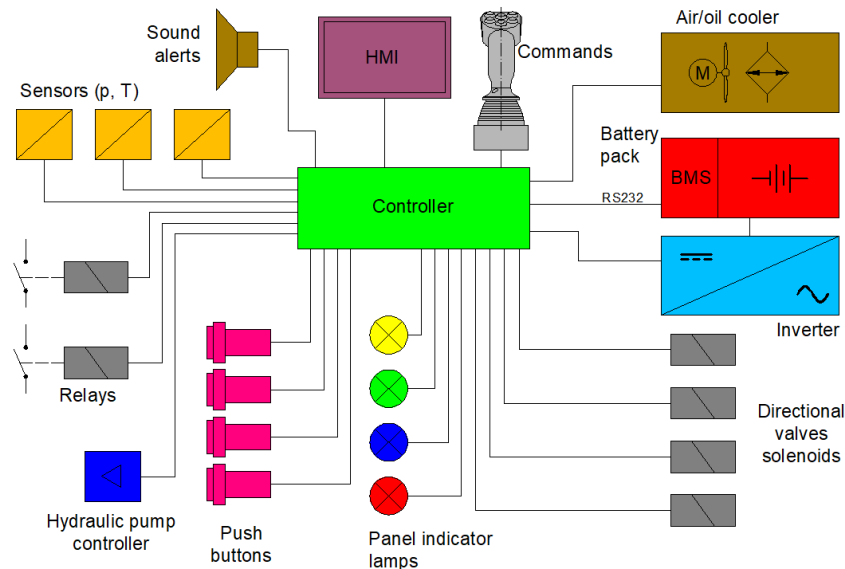

Fig. 11. The block diagram of the utility vehicle command and control system

Analogue outputs of the PLC, control the hydraulic pump controllers and the frequency of the inverter. Through a serial communication, information is received about the state of charge (SoC), voltage and temperature, as well as alerts from the battery management system (BMS) of the battery

pack. Some information of interest is accessible to the driver, and others can only be visible when the machine's service mode is activated.

In works [19, 20], the authors studied and tested systems and strategies of control for hybrid machinery. Through the human-machine interface (HMI), the driver can view information, during the operation of the machine, regarding the status of the controls, the operating mode, the power used by the electric motor, the charging status of the battery and the temperatures of: ambient, electric motor, diesel engine, battery pack and hydraulic fluid. In the PLC program, a series of automations are also realized, for example hydraulic fluid thermostating, thresholds regarding audio and visual alerts related to temperatures, pressures, SoC etc. Interlocks are also implemented in the PLC so that some commands cannot be overlapped, which can lead to the failure of some equipment.

5. Summary

The vehicle can be supplied with power from an electric motor and an internal combustion engine, and the battery can only be charged from the grid.

The vehicle can be used in spaces where should not be polluting emissions such as tunnels without forced ventilation, underground parking lots or other areas.

The vehicle can be the basis for a further development of a full electric utility vehicle with greater autonomy.

Auxiliary equipment with hydraulic actuation can be mounted on the vehicle to carry out various works.

The electrical installation is modern, being based on a programmable controller that fulfills multiple functions.

Acknowledgements

This paper has been financed under a project funded by the Ministry of Research, Innovation and Digitalization through Programme 1- Development of the national research & development system, Sub-programme 1.2 - Institutional performance - Projects financing the RDI excellence, Financial Agreement no. 18PFE/30.12.2021.

References

- [1] Liu H., Xiong Y.-P., Zhao Q.: Research status and development trends of petrol-electric hybrid construction machinery. 45. 166-171, 2017
- [2] Bian Y., Jiang J., Shen R., Jing Z., Li A., Wu H.: Recent Patents on Hybrid Construction Machinery. Recent Patents on Mechanical Engineering. 6. Pp. 97-106, 2013. DOI: 10.2174/2212797611306020002
- [3] Lin T., Wang Q., Hu B., Gong W.: Development of hybrid powered hydraulic construction machinery. Automation in Construction - AUTOM CONSTR. 19, pp.11-19, 2010. DOI: 10.1016/j.autcon.2009.09.005
- [4] Kalociński T.: Modern trends in development of alternative powertrain systems for non-road machinery. Combustion Engines. 188, 2021. DOI: 10.19206/CE-141358
- [5] Schwaderlapp M., Bülte H., Plumpe A.: Solutions for CO₂-Free Powertrains for Mobile Machinery. In Heavy-Duty-, On-und Off-Highway-Motoren 2021: Die Zukunft des Verbrennungsmotors und der alternativen Antriebe, pp. 8-17, 2022. Wiesbaden: Springer Fachmedien Wiesbaden. https://link.springer.com/chapter/10.1007/978-3-658-38105-9_2
- [6] Yan L.-J., Sun H., Liu W., Jiang J.-H., Zhao Y., Han J.-W.: Hydraulic hybrid technology of moving construction machinery. Jilin Daxue Xuebao (Gongxueban)/Journal of Jilin University (Engineering and Technology Edition), 2014. 44(2), pp. 364-368. DOI: 10.13229/j.cnki.jdxbgxb201402014
- [7] Goswami G., Jaiswal S., Nutakor C., Sopanen J.: Co-Simulation Platform for Simulating Heavy Mobile Machinery with Hydraulic Actuators and Various Hybrid Electric Powertrains. IEEE Access 2022, 10, 105770-105785. DOI: 10.1109/ACCESS.2022.3211523



- [8] Liukkonen M., Hentunen A., Suomela J., Kyyra J.: Functional Simulations of Power Electronics Components in Series-Hybrid Machinery for the Needs of OEM, 2008
- [9] Yang J., Liu B., Zhang T., Hong J., Zhang H.: Application of energy conversion and integration technologies based on electro-hydraulic hybrid power systems: A review. *Energy Conversion and Management*. 272, 116372, 2022. DOI: 10.1016/j.enconman.2022.116372
- [10] Ratzinger J., Buchberger S., Eichlseder H.: Electrified powertrains for wheel-driven non-road mobile machinery. *Automotive and Engine Technology*. 6, pp. 1-13, 2021. DOI: 10.1007/s41104-020-00072-z
- [11] Yang N.A., Luo Ch., Li P.: Design and performance analysis on a new electro-hydraulic hybrid transmission system. *International Journal of Electric and Hybrid Vehicles*. 9, 134, 2017. DOI:10.1504/IJEHV.2017.085343
- [12] Scolaro E., Beligoj M., Perez Estevez M., Alberti L., Renzi M., Mattetti M.: Electrification of Agricultural Machinery A Review. *IEEE Access*. PP. 1-1, 2021. DOI: 10.1109/ACCESS.2021.3135037
- [13] Bradu C., Ianuș G.: A prospective view on biodegradable lubricants for hybrid and electric vehicles. *IOP Conference Series: Materials Science and Engineering*. 1262, 012001, 2022. DOI: 10.1088/1757-899X/1262/1/012001
- [14] Edamura M., Ishida S., Imura S., Izumi S.: Adoption of electrification and hybrid drive for more energy-efficient construction machinery. 62., pp. 118-122, 2013
- [15] Wang H.: The Design of the Hybrid Energy Storage System in Hybrid Construction Machinery. *Advanced Materials Research*. 875-877, 1934-1938, 2014. DOI: 10.4028/www.scientific.net/AMR.875-877.1934
- [16] Zhang, Haoxiang & Wang, Feng & Bing, Xu & Fiebig, Wieslaw. (2022). Extending battery lifetime for electric wheel loaders with electric-hydraulic hybrid powertrain. *Energy*. 261. 125190. DOI: 10.1016/j.energy.2022.125190
- [17] Hu P., Zhu J., Gong J., Zhang D., Liu Ch., Zhao Y., Guo Y.: Development of a Comprehensive Driving Cycle for Construction Machinery Used for Energy Recovery System Evaluation: A Case Study of Medium Hydraulic Excavators. *Mathematical Problems in Engineering*. pp. 1-13, 2021. DOI: 10.1155/2021/8132878
- [18] Sugano N., Nanjyo T., Imanishi E., Yoshimatu H., Uejima M.: 215 A Study on the Efficiency of Swing System of Hybrid Construction Machinery. *The Proceedings of the Dynamics & Design Conference*. 2003. _215-1_. 10.1299/jsmedmc.2003.215-1_
- [19] Paganelli G., Tateno M., Brahma A., Rizzoni G., Guezennec Y.: Control development for a hybrid-electric sport-utility vehicle: Strategy, implementation and field test results. *Proceedings of the American Control Conference*. 6. 5064 - 5069 vol.6, 2001. DOI: 10.1109/ACC.2001.945787
- [20] Zhao P.-Y., Chen Y.-L., Zhou H.: Overview of hydraulic hybrid engineering machinery system and control strategy. 50, pp: 449-459, 2016. DOI: 10.3785/j.issn.1008-973X.2016.03.008

